

TIMEGUARD®

Professional Rewireable Floodlight



LEDPR070B
Black

LEDPR070WH
White

LEDPR0100B
Black

LEDPR0100WH
White



Installation & Operating Instructions

1. General Information

These instructions should be read carefully in full before installation and retained for further reference and maintenance.

2. Safety

- Before installation or maintenance, ensure the mains supply to the floodlight is switched off and the circuit supply fuses are removed or the circuit breaker turned off.
- It is recommended that a qualified electrician is consulted or employed for the installation of this floodlight and that it is installed in accordance with current IEE wiring and Building Regulations.
- Check that the total load on the circuit including when this floodlight is fitted does not exceed the rating of the circuit cable, fuse or circuit breaker.
- DO NOT place any object closer than 1 metre in front of the floodlight.

3. Technical Specifications

- 230V AC 50Hz
- This PIR sensor is of class I construction and must be earthed
- Colour Temperature: 4000K
- Energy Efficiency: Class F
- Operating Temperature: -20°C to +40°C
- IP65 Rated, suitable for restricted external applications
- Dimensions (H x W x D): 235 x 305 x 66mm
- CE Compliant

LEDPRO70B & LEDPRO70WH

- 70W LED Non replaceable lamp
- Energy Usage: 70kWh/1000h
- Lumen Output: Black = 7800lm, White = 7800lm

LEDPRO100B & LEDPRO100WH

- 100W LED Non replaceable lamp
- Energy Usage: 100kWh/1000h
- Lumen Output: Black = 12,000lm, White = 12,000lm

4. Installation

- Ensure the mains supply is switched off and the circuit supply fuses are removed or the circuit breaker turned off.
- An isolating switch should be installed to enable the power to be switched ON and OFF to the floodlight. This allows the unit to be easily switched OFF for maintenance purposes.

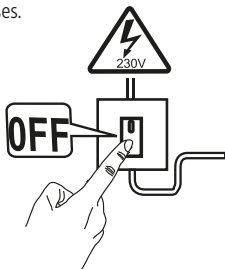

- Mark the position of the mounting holes on the wall using the U bracket supplied as a template.

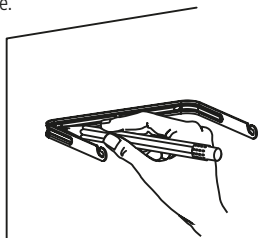

- Drill the holes for the wall plugs ensuring not to infringe on any gas/water pipes or electrical cables that may be hidden below the surface.

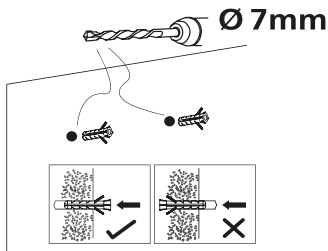

- Fix the U bracket to the wall using the correct screws for the wall plugs being used.
Note: Ensure that when you mount this, the slots at the end of the bracket open upwards to allow you to easily attach and secure the floodlight when ready.

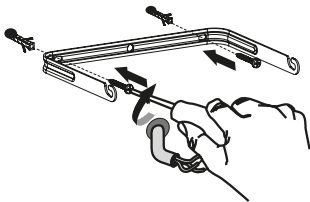

- Attach the floodlight to the U bracket fitted to the wall. You can pre-fit the supplied fixing screw/bolt and washers to the floodlight before you do this, the screws/bolts will just need to be loose enough to fit over the upward-facing slots at the end of the U bracket. Make sure the washers are in the correct order as per the diagram. When the floodlight is in place, secure the screws/bolts, ensuring not to overtighten.

3

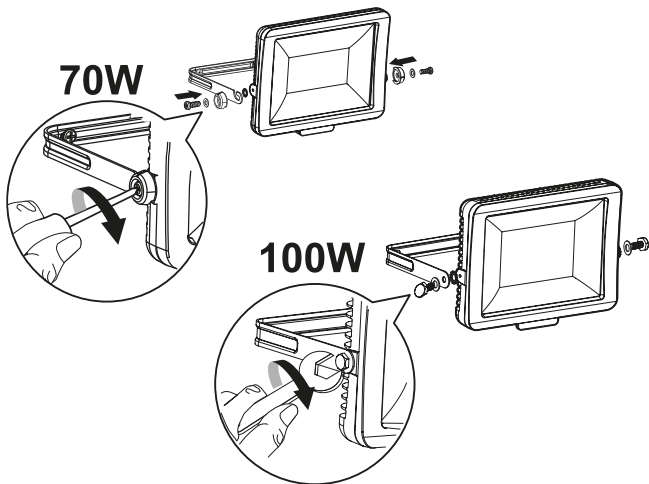

- Pass the supply cable through the holes(s) provided in the backplate ensuring that a cable gland, grommet or sealing compound is used to maintain the IP rating of the floodlight.

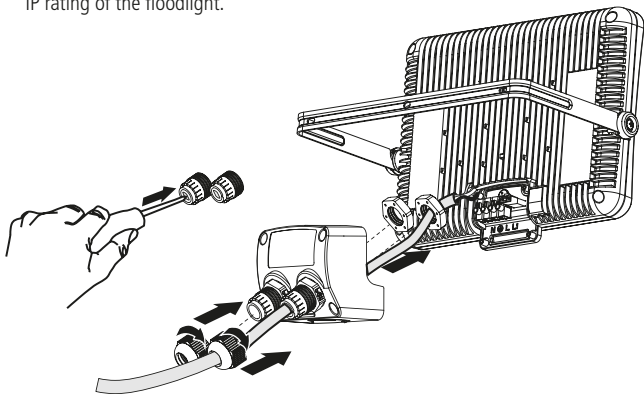

4

- Terminate the supply cable into the terminal block (see section 5. Connection diagram) ensuring correct polarity is observed and that all bare conductors are sleeved.
- Attach the backplate to the floodlight, and apply pressure to the top and bottom, then secure all four fixing screws ensuring not to overtighten.

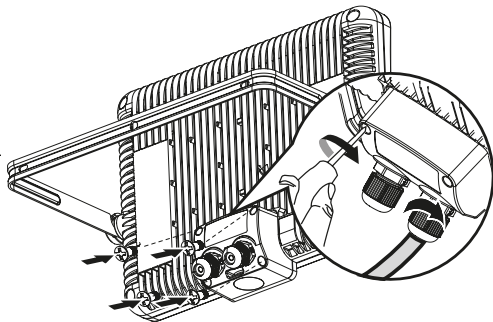

5. Connection Diagram

- Connect the 230V 50Hz mains supply cable as follows;

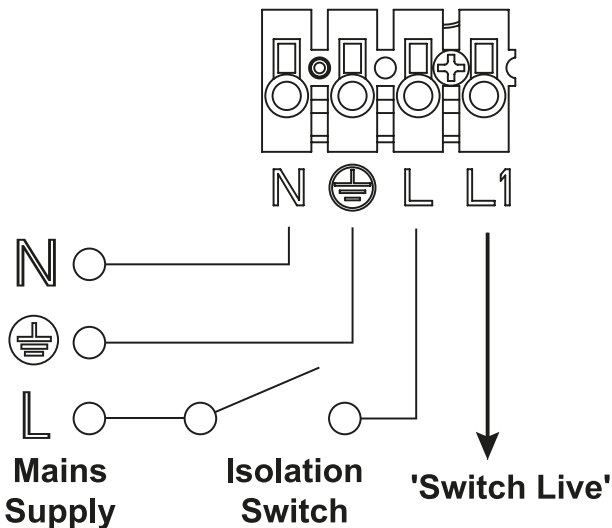

230V 50Hz Mains Supply

Live Supply (Brown or Red) to

Neutral Supply (Blue or Black) to

Earth (Green/Yellow) to

L

N



Note: the L1 terminal is a Switch Live "Live Output" for slave floodlights (when used in conjunction with the Timeguard LEDPROSLB-WH, LEDPRORFKB-WH PIRs or the LEDPROPCB-WH Photocell).

6. Operation

- Turn the power ON and test for normal operation.

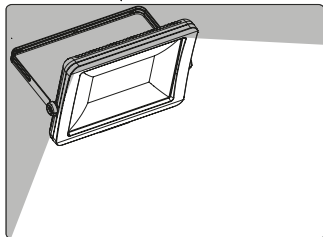

7. Lamp Adjustment

- The floodlight can be tilted as per the diagram.

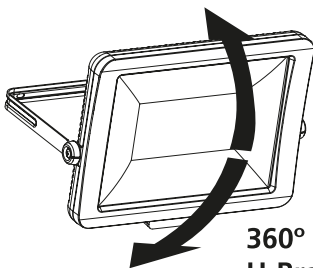

**360° turn through
U-Bracket**

3 Year Guarantee

In the unlikely event of this product becoming faulty due to defective material or manufacture within 3 years of the date of purchase, please return it to your supplier in the first year with proof of purchase and it will be replaced free of charge. For years 2 and 3 or any difficulty in the first year, telephone the helpline on 020 8450 0515.

Note: A proof of purchase is required in all cases. For all eligible replacements (where agreed by Timeguard) the customer is responsible for all shipping/postage charges outside of the UK. All shipping costs are to be paid in advance before a replacement is sent.

If you experience problems, do not immediately return the unit to the store. Telephone the Timeguard Customer Helpline:

HELPLINE

020 8450 0515

or email helpline@timeguard.com

Qualified Customer Support Coordinators will be online to assist in resolving your query.



A **theben** Group Company

For a product brochure please contact:

Timeguard Limited.

Victory Park, 400 Edgware Road,

London NW2 6ND

Sales Office: 020 8452 1112

or email csc@timeguard.com

www.timeguard.com